

**Rod Seal Leakage Control of
Non-Elastomeric Seals by Method of
Contact Pressure Analysis**

by

Jeff Spira

**R&D & Liasion Engineering
Sargent Aerospace
Yorba Linda, California**

**Presented to
National Fluid Power Association
Aerospace Committee
Cleveland, Ohio
October 4, 1990**

Rod Seal Leakage Control of Non-Elastomeric Seals by Method of Contact Pressure Analysis

by Jeff Spira

Abstract

This paper presents a method of estimating non-elastomeric rod seal leakage in hydraulic actuators by method of contact pressure analysis. This method first examines the true pressure cycle of rod seals and determines the points of the cycle when the leakage is highest. The dynamics of the seal surface to gland wall pressure are then examined to determine both the causes of leakage and the method of controlling the leakage. Empirically established minimum contact pressures for leakage control are offered for various common non-elastomeric sealing materials.

Introduction

It is commonly believed that fluid power sealing is a "black art" or that it is only performed by "feel". This mis-conception is widely perpetrated throughout the fluid handling and fluid power industry. Nothing could be farther from the truth. Fluid sealing, like all other physical phenomena in our world is subject to physical laws and determinable through the application of physics and mathematics to the problem.

It is to this end that this paper has been prepared: to introduce the seal designer or seal user to the physical principles of sealing and to back up these principles with provable mathematical models of real world sealing problems.

The Rod Seal

Of all of the applications where seals are required, few applications are more difficult to seal than the reciprocating rod seal. The rod seal is dynamic, complicating the already difficult task of sealing two surfaces with a pressure applied across them. The rod seal also has a leak path directly external to the device. Rod seal leakage is painfully obvious as the sealed media is seen dripping or spraying out of the actuator or other sealed device. Contrast this to piston seals, whose leakage is generally measured only as pressure loss across the internal piston of the device. As long as a piston seals pressure, the sealed device generally works even though a considerable amount of fluid may be passing between the two sealed surfaces. Rod seals are never afforded this luxury.

Piston seals nearly always have a large pressure differential across themselves whereas rod seals do while retracting and almost never do while extending. To fully understand rod seal sealing principles, the rod seal true cycle must be examined.

Rod Seal True Cycle

On hydraulic and pneumatic linear actuators, the rod seal provides the primary fluid and pressure retention device at the only real externally accessible dynamic joint. Actuators extend by the introduction of pressureized fluid to the blind end of the cylinder, forcing the piston to move away from the blind end which in-turn displaces the fluid from the rod end of the actuator. Similarly the actuator retracts when pressureized fluid is introduced into the rod end of the cylinder forcing the piston toward the blind end displacing fluid from the blind end volume.

To examine the actual conditions at the rod seal in more detail, the retraction stroke presents a higher differential pressure at the rod seal while the rod passes the seal from the external environment into the fluid environment. Extension presents the rod seal with a lower, sometimes near-zero differential pressure across the seal while the rod is passing from the fluid media environment to the external environment. This principle is illustrated in Figure 1.

As the cylinder approaches the end of its stroke and decelerates either through the closing of the valve, the approach of the limit of the cylinder load capacity (as in the case of a clamp or press), or through cushioning devices, the pressure differential across

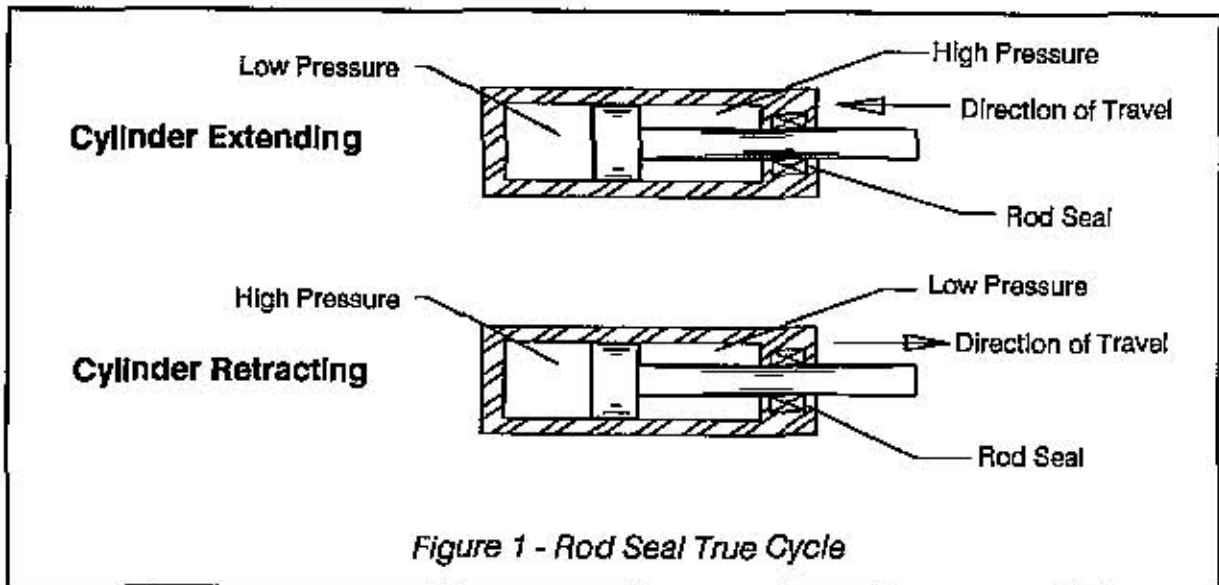

Figure 1 - Rod Seal True Cycle

the rod seal to the external environment can approach and even exceed zero while the rod is still moving slightly.

The rod passing by the cylinder has an ability to carry the fluid media along with itself in a boundary layer. The boundary layer shear principle is the primary force in operation in hydrodynamic bearings, that is, hydrodynamic bearings are able to separate sufficiently to achieve non-contact riding on a fluid film generated by the boundary layer shear principle. The rod seal in a hydraulic actuator is exposed to exactly the same separating forces as the hydrodynamic bearing when the cylinder extends.

Presupposing mechanical or pressure damage, it is in the extension stroke when the differential pressure is lowest and the rod is passing out of the cylinder, that rod seals exhibit the greatest leakage. It is also in this condition that worn seals will first exhibit wear leakage.

Return Pressure

It is conventional in industrial and mobile hydraulic systems to provide the lowest pressure path possible for return fluid flow. This allows the highest differential pressure possible equating to the most power output across the actuating devices. Frequently this return pressure is generated only by pipe friction and valve orifice losses. Typically this is 50 psi or less in well designed systems.

In aerospace hydraulic systems, this is not the case. Return pressure is intentionally generated to permit servo-systems a faster reaction time and to prevent the natural G forces from causing cavitation due to near zero pressures in violent maneuvering. Typically a return pressure regulating device is used to generate a backpressure in the 50 - 200 psi range.

Seal to Gland Wall Contact

It is fairly obvious that the effectiveness of a seal is related to the seal gland wall contact. This is the actual area that effects a fluid seal. This seal to gland contact area must cut off the flow of the fluid between the seal and the wall.

If the seal to gland area were magnified, the surface finish would appear erose and irregular. Disregarding macro damage to either surface, it is between these surfaces that the fluid flows. The fluid twists and turns its way through the microscopic valleys and irregular paths between the two materials from the higher pressure areas to the lower.

The only way to stop this fluid flow through the irregularities of the materials is by forcing the two materials together with sufficient pressure to block these fluid paths. This pressure is termed the seal's Contact Pressure (P_C).

In nearly all cases, the seal material is several orders of magnitude less deformable than the mating surface (the rod surface in the case of a dynamic rod seal) so any deformation of the rod material may be ignored. The seal material must then deform sufficiently to block the fluid passage between the two erose surfaces. The minimum amount of pressure required to fully cut off this seal path is then P_{Cmin} .

Pressure is defined as force divided by the area:

$$P = \frac{F}{A}$$

Where:

P = Pressure (psi)

F = Force (lbs.)

A = Area (in^2)

To restate this as seal contact pressure

$$P_C = \frac{F_I}{A_C}$$

Where:

F_I = The internal forces exerted toward the rod

A_C = Contact area of the seal against the rod

Internal Forces Exerted Toward the Rod

In a seal there are two distinct forces assisting the seal to make its required contact pressure against the rod. These are the expander force and the pressure induced force. The two forces summed generate the total internal force, F_I .

The expander forces are caused by either the design of the seal, if it is elastically compliant or by an expander device, either an elastomeric or metallic element of the seal.

For the purposes of this paper, since it deals with non-elastomeric seals, the first condition, forces induced by the design of the seal, is minor since most of the materials have very little elasticity in normal designs. The second case, an elastomeric or metallic expander element induced force will be examined.

Figure 2 shows several common seal configurations using both elastomeric and metallic seal expanders.

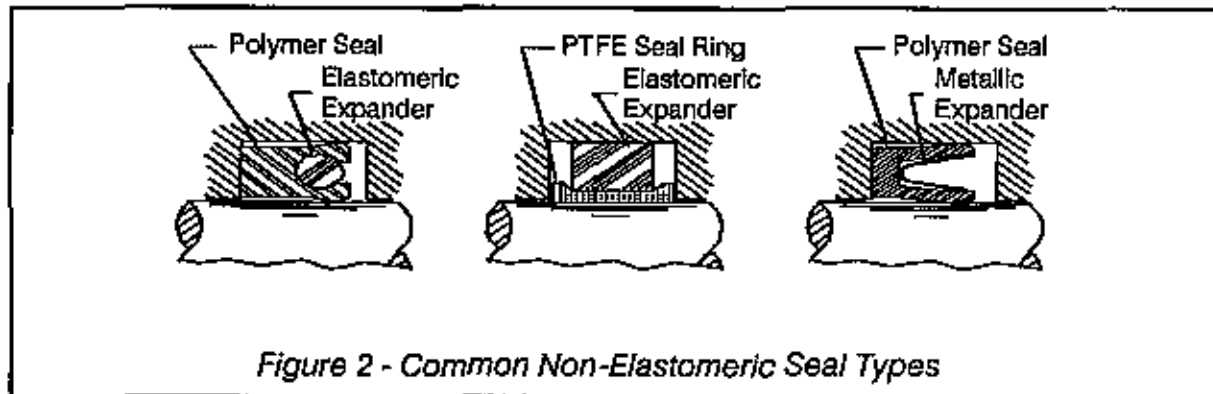

In each of the three seals shown in figure 2, an element either elastomeric or metallic, provides a static force against the sealing surface directed toward the rod. In the case of the elastomeric energized seals, this force is generated by the compression of the elastomer. In the case of the spring energized seal, this force is created by the deflection of the metallic spring element. In all cases this force is static and independent of pressure. With the elastomeric seals it may be dependent on the sealed media (chemical swell) or temperature as well.

The static energizer force is independent of pressure and may be calculated by the amount of deflection of the energizer. For the elastomeric energizer it is calculated by first applying the stress strain relationship:

$$E = \frac{S}{e}$$

Where:

E = Compressive Modulus of the material (psi)

S = Stress level in material (psi)

e = Strain (in/in or %) (deflection / free height of elastomer)

Once the stress level is known, the force is calculated with the basic stress relationship:

$$F_s = \frac{S}{A}$$

Where:

F_s = Force (lbs)

S = Stress (psi)

A = Projected area of expander (in²)

For a metallic spring energizer of the type shown, a cantilever beam equation is solved for deflection and reduced to the equation:

$$F_s = \frac{K I}{P}$$

Where:

K = Spring Rate (lb/in)

I = Interference (in)

P = Spring Pitch Length (in)

Note:

All of the equations above calculate the force of the expander per unit of circumferential seal length, that is, each equation results in a force for a single inch of seal. When these equations are later expanded to calculate pressure, this factor will be accounted for.

In addition to the static force generated by the expander, an additional force is generated in the seal from the sealed pressure. This force is a function of the internal area of the seal projected radially toward the rod. For purposes of calculation, the elastomeric element can be considered a fluid, exerting system pressure against the seal element.

For purposes of determining the sealability of a rod seal, the pressure used for the pressure induced force should be the return pressure of the system. It is often useful to use a zero system pressure value for purposes of static leakage, however, in nearly all aerospace hydraulic systems, some return pressure is present, so this return pressure may be used.

To calculate the pressure induced force (again, per unit length):

$$F_p = P_s \times W$$

Where:

F_p = Force (lbs)

P_s = System Pressure (psi)

W = Internal axial length of seal exposed to pressure (inches)

The W number to use is illustrated in figure 3.

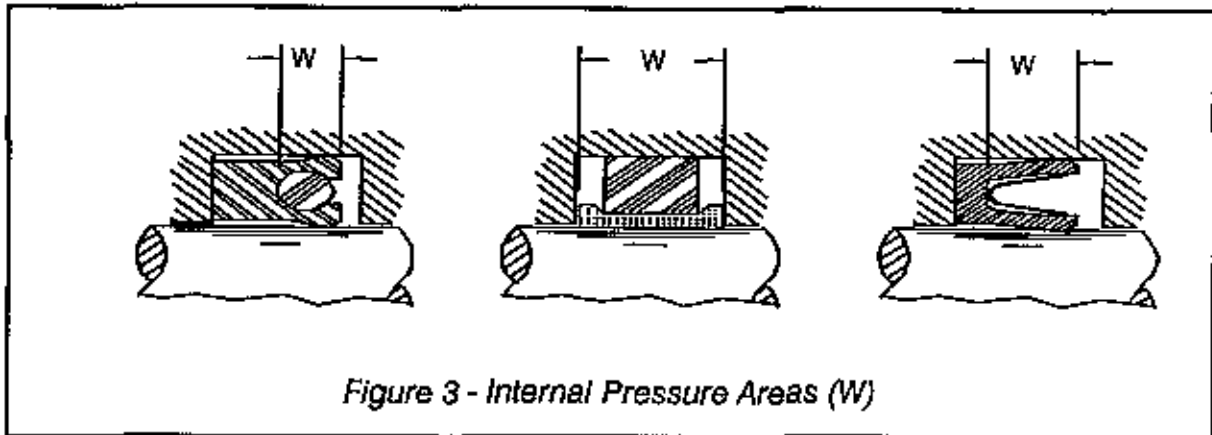

Figure 3 - Internal Pressure Areas (W)

Contact Pressure Calculation

Returning to our contact pressure equation and substituting the forces into the equation and accounting for the seal diameter results in:

$$P_c = \frac{\pi d F_s + \pi d F_p}{\pi d L_c}$$

Where:

P_c = Contact Pressure (psi)

d = Seal diameter (at energizer location) (in)

L_c = Axial Contact Length of Seal (in)

The π 's and d 's may be factored out to arrive at the final seal contact pressure equation:

$$P_c = \frac{F_s + F_p}{L_c}$$

The most difficult value to determine in this equation is L_c . This value may be directly measured (in the case of a seal with a flat contact surface) or approximated or tested in the case of a rounded or pointed contact surface. This L_c value is sometimes

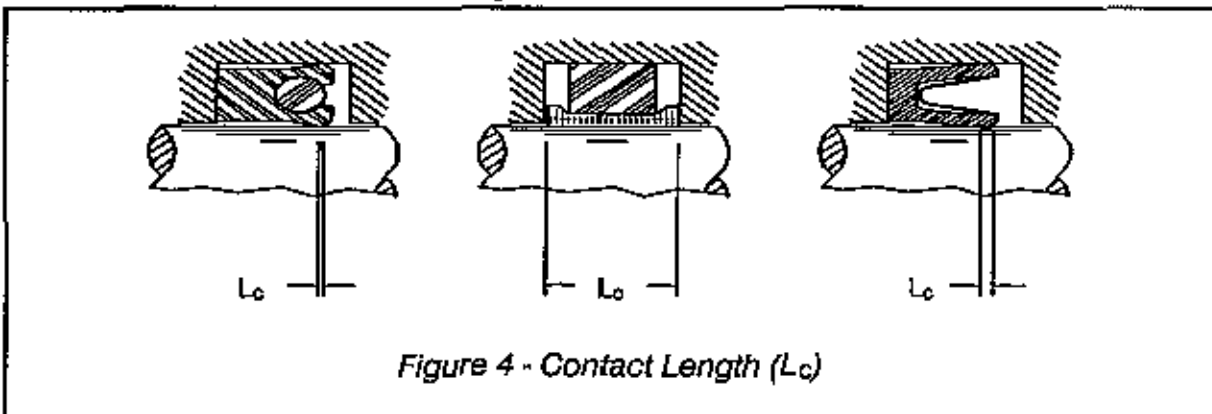

Figure 4 - Contact Length (L_c)

referred to as the seal's footprint. A clear acrylic gland can sometimes be made up with the seals installed to determine the L_c of a particular seal design. Figure 4 illustrates L_c .

Using P_c

Once the contact pressure is established, the question arises as to how much contact pressure is required. If P_c is excessive, the seal will wear excessively and friction will be high. If the p_c is too low, leakage will be excessive.

The amount of contact pressure required is a function of the material used for the seal and the surface finish of the rod. This relationship may be expressed as:

$$P_{Cmin} = \frac{E_c}{K_p}$$

Where:

P_{Cmin} = Minimum required contact pressure (psi)

E_c = Compressive modulus of material (psi)

K_p = Contact Pressure Constant

The contact pressure constant (K_p) is not a constant but rather varies with surface finish. An insufficient amount of empirical data has been collected to really establish firm quantities, but from some tests performed both in the laboratory and in field testing of hydraulic systems, the following K_p values can be approximated:

Surface Finish - μ in	K_p Minimum
< 8	300
10 - 16	215
20 - 32	165
40 - 64	120

Conclusion

The topic of contact pressure is the root of rod seal sealing. No seal companies to date have stepped up to establish a science of sealability in non elastomeric seals. Often rod seal users must test a variety of seal designs and configurations until a workable seal is found. Simple contact pressure analysis of seals prior to testing will isolate the few designs that show promise for a specific application.

As in all discussions such as this, many variables are omitted for clarity. For instance the actual profile of a micro-finish and the direction of the lay are variables that will greatly affect the required contact pressure. Much more testing and analysis is required to truly understand the effect of contact pressure on rod seal sealing.